

## DRAWING (mm)

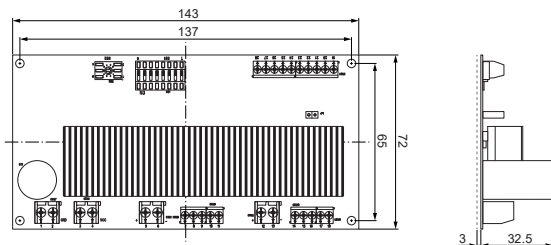

## PHOTO

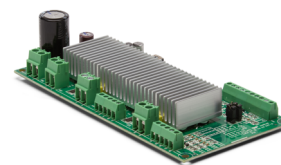

## MODEL NO. DESIGNATION

DDMS - NUMBER OF ACTUATORS

Example: DDMS-2

## ACCESSORIES



C = customizations are offered on demand even for smaller quantities. Typical customizations are indicated with a green dot at column end. Please contact us for any customization request.

ACTUATOR CONTROL BOX DATA		C
Mode <sup>1</sup>	Synchronous and asynchronous	
Number of actuators	2	
Compatible controller <sup>2</sup>	HDL-DDMS-2	
Compatible actuators <sup>3</sup>	Transmotec DLA series, DLB series, and DMA series.	
Output voltage	V	12   24
Output current <sup>4</sup>	A	25
Overload protection current <sup>5</sup>	A	2 to 25
Duty cycle <sup>6</sup>	%	15   40
Input voltage range <sup>7</sup>	V	12   24
Power cable <sup>8</sup>	Not included	
Power cable length <sup>8</sup>	m	Not included
CE label	Yes	
EMC	EMC Directive 2014/30/EU	
Operating temperature	°C	-20 to 55
Weight	g	150

## DIP SWITCH

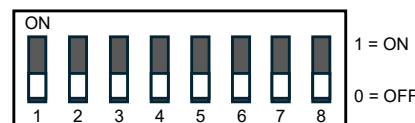

## DIP SWITCH SETTINGS

Definition	Number	Setting
No soft start/stop.	1, 2	00
0.5 second soft start/stop.	1, 2	01
1 second soft start/stop.	1, 2	10
2 second soft start/stop.	1, 2	11
If Hall effect sensor connected, sets the limit position at 40 pulses before both mechanical limits.	3, 4	00
If potentiometer connected, sets the limit position at 2% of the full stroke before both mechanical limits.	3, 4	01
If Hall effect sensor connected, sets the limit position at 20 pulses before both mechanical limits.	3, 4	10
If potentiometer connected, sets the limit position at 1% of the full stroke before both mechanical limits.	3, 4	11
If Hall effect sensor connected, sets the limit position at 10 pulses before both mechanical limits.	3, 4	00
If potentiometer connected, sets the limit position at 0.5% of the full stroke before both mechanical limits.	3, 4	01
No software limit. Only selectable under the actuator with physical limit switch.	3, 4	11
Dual Hall effect sensors.	5, 6	00
Single Hall effect sensors.	5, 6	01
Potentiometer	5, 6	10
No positioning sensor.	5, 6	11
2 connected actuators.	7	0
1 connected actuator.	7	1
Switch control mode.	8	0
Position input mode.	8	1

## OPERATION GUIDANCE

Control the actuator to extend and retract by swapping the DC input polarity.

To prevent voltage drop issues, use a power cord with a large cross-sectional area. Keep the wire length from the power supply to the control board and from the control board to the actuator motor as short as possible, ideally under 1 meter.

It is strongly recommended to install a max. 50 A slow-blow fuse between DDMS-1 and the power supply.

If the actuators have no positioning sensor, they must have limit switches that can cut off the power and stop by themselves, otherwise there is a high risk of damage to DDMS-1.

The speed of actuators controlled by DDMS-1 will be lower than the typical values stated in the actuator's data sheet. The maximum speed loss is up to 25%.

## NOTES

- Synchronous control requires the actuator to have a positioning function of Potentiometer, single Hall or Dual Hall. If the actuators have no positioning function, they must have the stroke limit switches at both ends to stop by themselves.
- Sold separately. See [www.transmotec.com](http://www.transmotec.com).
- 12 V DC or 24 V DC motor, and the speed can be adjusted by input voltage.
- Max. current limit for each actuator.
- Ten levels adjustable overcurrent protection setting.
- 2x20 A at 15% duty cycle, max. 40 seconds continuous operation in 4.5 min. 2x10 A at 40% duty cycle, max. 2 min. continuous operation in 5 min.
- Nominal voltage range 12 V or 24 V.
- Cables not included. Recommended specification for use is AWG10 or AWG12, length 1 m.

## FRONT AND REAR TERMINALS

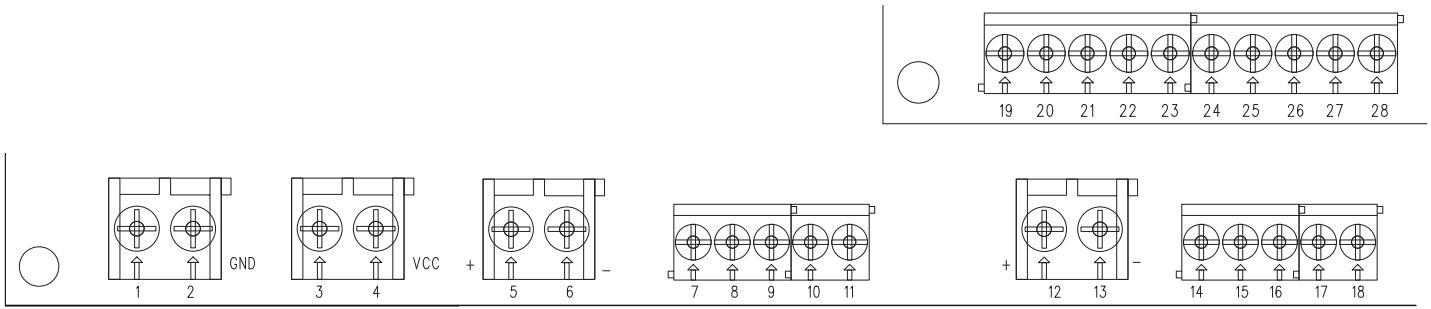

## FRONT AND REAR TERMINAL CONFIGURATION

Terminal <sup>1</sup>	Definition	Description	Recommended wire gauge
1 and 2	V-	Ground.	AWG14   AWG12 <sup>2</sup>
3 and 4	V+	Nominal 12 V or 24 V (acceptable input voltage range 9 V ~ 32 V).	AWG14   AWG12 <sup>2</sup>
5 and 12	M+	12 V or 24 V DC output. When controlling the actuator to extend, M+ and M- are VDC+ and VDC-, respectively. When retracting the actuator, the polarity is reversed.	AWG20 ~ AWG12
6 and 13	M-		
7 and 14 <sup>3</sup>	H1   Hall 1 input	Hall signal 1 input.	AWG24 ~ AWG18
8 and 15	H2   Hall 2 input	Hall signal 2 input.	AWG24 ~ AWG18
9 and 16	POT	Voltage input from potentiometer. Wiring according to "POTENTIOMETER WIRING".	AWG24 ~ AWG18
10 and 17	Vout	5 V power output, for the actuator's Hall module or Potentiometer, depending on which is present.	AWG24 ~ AWG18
11 and 18	GND	Ground.	AWG24 ~ AWG18
19	5 V out	5 V output to the switch.	
20	RET	Retraction signal input. Can use 5 V of terminal 19 or external 5 V power source. Actuator retracts when switch on.	
21	EXT	Extension signal input. Can use 5 V of terminal or external 5 V power source. Actuator extends when switch on.	
22	Learning	Learning signal input. Can use 5 V of terminal 19 or external 5 V power source. Triggered after switching on for more than 2 seconds, the system will automatically learn the stroke of the actuators.	
23	Fault out	Error signal output. Outputs a 5 V signal when reaching overcurrent, or when the feedback signal of the actuator is lost.	
24	EMS	Input signal for emergency stop switch (Normally Closed). For customer to install emergency stop switch between terminals 19 and 24. To use this function, the JP1 jumper must be removed.	AWG24 ~ AWG18
25	Analog position in	Analog signal (0 ~ 5 V) to run the actuator to the specified position. The control signal can be generated using an external power source or using the 5 V at pin 27 via a potentiometer. It is forbidden to input PWM signal.	
26	Position OK	In-position signal output. When using the position input mode, the actuator will output a signal (5 V) after reaching the specified position (according to input from terminal 25).	
27	5 V out	5 V power supply to the position input mode of control circuit.	
28	GND	Ground. When using the position input mode, the GND of the power source must be connected here.	

## POTENTIOMETER WIRING

## HALL SIGNAL DATA

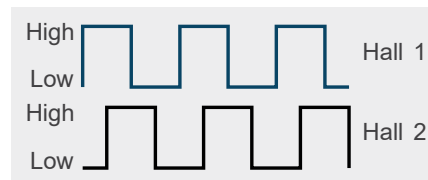
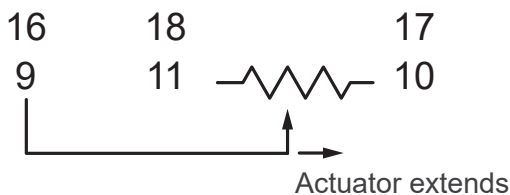

## OVERCURRENT PROTECTION

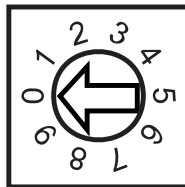

## OVERCURRENT PROTECTION SETTINGS

Rotary switch setting	0	1	2	3	4	5	6	7	8	9	
Max. current	A	2	3	4	6	8	10	13	15	20	25

## NOTES

- When controlling a single actuator, only use terminals 5, 6, 7, 8, 9, 10, 11.
- For load currents under 30A, use a single AWG12 wire. For load currents between 30 A and 50 A, use two AWG14 wires or larger in parallel.
- When controlling a single Hall sensor actuator, only use terminals 7 and 14.